

Y0 - 0000 - 1FFF H
 Y1 - 2000 - 3FFF H
 Y2 - 4000 - 5FFF H
 Y3 - 6000 - 7FFF H
 Y4 - 8000 - 9FFF H
 Y5 - A000 - BFFF H
 Y6 - C000 - DFFF H
 Y7 - E000 - FFFF H

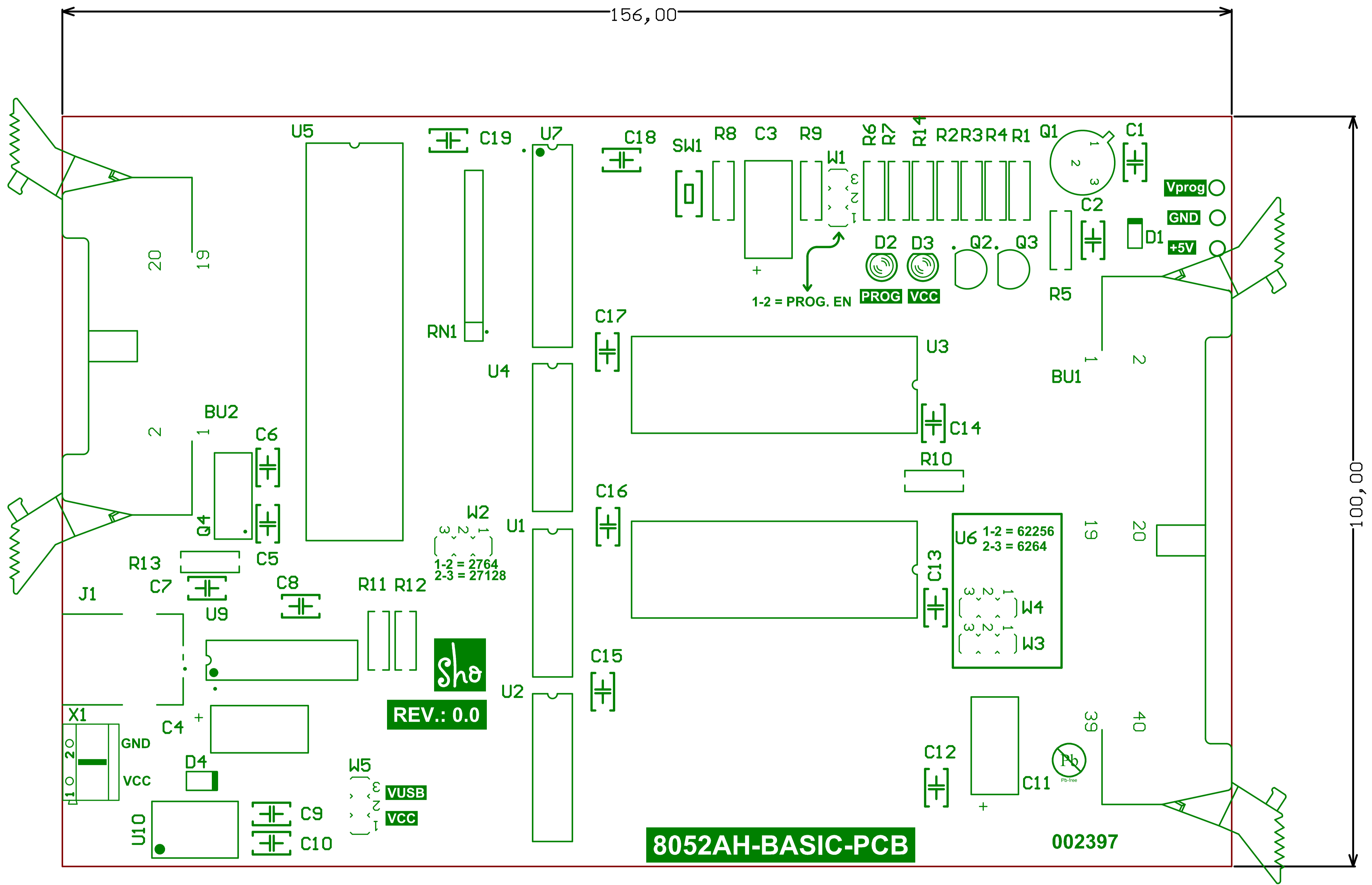



Bearbeiter: S. Hofmann
 Tel: 040 /
 Fax: 040 / 76906856
 Email: shop@shotech.de

Bill of Materials

Datum:	29. November 2023
Zeit:	12:03:11
Variante:	Variant of P8052AH-1-ALL
Bezeichnung:	8052AH-BASIC Board
Revision:	0.0
Description:	PCB

Quantity	Designator	Footprint	Bemerkung	Value	MFT	Order-Code	Second-source	shotech
1	BU1	IDC2.54-H40A - duplicate	SEK-18 SV MA STD ANG29 RKZ 40P PL3	09 18 540 7903	Harting	09 18 540 7903	PSL-40W	
1	BU2	IDC2.54-H20A	SEK-18 SV MA STD ANG29 RKZ 20P PL3	PSL 20W	Harting	09 18 520 7913	Reichelt - PSL 20W	
10	C16, C17, C18, C19	CAP_Radial_5MM	100nF/50V/±10%/X7R/RM 5.08	100nF/50V	Vishay / BC Components	K104K15X7RF53H5	C322C104K5R5TA - shotech	1347
2	C3, C4	CAPPA6.3mm x 13mm	Elko axial 100µF 16V 6.3x13mm +85°C	10µF/35V	SUNTAN	TS13AE1V100MSB000R		
2	C5, C6	CAP_Radial_5MM	Ker-Ko 22pF 50V RM5.00 5% NPO/COG	22pF	TDK	FG28C0G1H220JNT06	FG28C0G1H220JNT00	2387
1	C7	CAP_Radial_5MM	COG +/-8% LS=5mm	330pF	TDK	FG26C0G2J331JNT06	3D06B331KL52N : Richwell	2396
1	C8	CAP_Radial_5MM	Vs-Kond 470nF 63V Z5U RM5	470nF	KEMET	C322C474M5U5TA	KEMET	1751
2	C9, C10	CAP_Radial_5MM	CAP CER 1uF 50V X7R RADIAL	1uF	KEMET	C330C105M5R5CA7303		1414
1	C11	CAPPA6.3mm x 13mm	Elko axial 100µF 16V 6.3x13mm +85°C	100µF/16V	SUNTAN	TS13AE1C101MSB000R		
3	CS1, CS2, CS3		Circuit socket DIP28-LC	Circuit socket DIP28-LC	ASS	A 28-LC-TT		1521
1	CS4		Circuit socket DIP40	Circuit socket DIP40	ASS	A 40-LC-TT		1582
3	CS5, CS6, CS7		Circuit socket DIP14 präzision	Circuit socket DIP14	PRECIDIP	110-87-314-41-001101		2065
1	CS8		Circuit socket DIP16 präzision	Circuit socket DIP16	ASS	AR16-HZL-TT		2066
1	CS9		Circuit socket DIP20 präzision	Circuit socket DIP20	ASS	AR 20 HZL-TT		2067
1	CS10		Ribbon cable yellow 28	Ribbon cable yellow 28	shotech			2398
1	CS11		Circuit IDC socket 40 pin.	pin.	frei	PFL 40		
1	CS12		Circuit IDC socket 20 pin.	pin.	frei	PFL 20		
1	D1	DO-35	Dioden (Allzweck, Leistung, Schaltung) Vr75V Iol/150mA T/R	1N4148	On Semiconductors	1N4148TR		1594
1	D2	LED3MM - spacer - red	LED diffus rot 80mcd 45° 3mm	LED_3mm_RED	Everlight	204-10SURD/S530-A3		1321
1	D3	LED3MM	LED diffus grün 50mcd 60° 3mm	LED_3mm_GREEN	Everlight	204-10SYGD/S530-E2		1323
1	D4	DO41	Schotky Dioden & Gleichrichter 1.0A 40V	1N5819	Taiwan Semiconductor	1N5819 R0		1568
1	J1	CON-A-USBSB	USB-Buchse B print 90°	USB-B	Ässmann WSW	A-USBSB		1618
1	KL1		Circuit board	Circuit board	frei			2397
3	PP1, PP2, PP3	PP-RTM1364E-Z	Lötstift quadr. 1,05x10mm verzinkt	RTM1364E-Z	Vogt	1364E.68		1570
1	Q1	TO-39	Bipolartransistor, PNP, 60V, 1.5A, 1.5W, TO-39	BC161-10	CDL	BC161-10		
2	Q2, Q3	SC_TO-92	Hole TO-92-3	BC547C	On-Semiconductor	BC547CBU		1169
1	Q4	HC49/4H_SMX	Quarze +/-30ppm, 20pF, 400Ohm, 11,059200MHZ FUNDAMENTAL	11.059200MHz	HKC Europe	9SM1105920E20F3F2000		1320
6	R1, R2, R3, R5, R6, R10	RES10-7.8x2.8 - 10k	WIDERSTAND, 207, axial, 1%	10k	frei	RMGK010		1233
1	R4	RES10-7.8x2.8	WIDERSTAND, 207, axial, 1%	4k7				1587
2	R7, R14	RES10-7.8x2.8 - 330R	WIDERSTAND, 207, axial, 1%	330R				1588
1	R8	RES10-7.8x2.8	WIDERSTAND, 207, 1%	100R				1678
1	R9	RES10-7.8x2.8	Metallsch. 0207 1/4W 1% 1K5 lose	8.2k		RMK001.5		
2	R11, R12	RES10-7.8x2.8 - 1k	Metallsch. 0207 1/4W 1%	1k	frei	RMGK001		1235
1	R13	RES10-7.8x2.8	WIDERSTAND, 207, 1%	1M				1668
1	RN1	SIP240W50P254L2276H508Q9P	Widerstandnetzwerke u. -Arrays 9pins 10Kohms Bussed	RN10k	Boums	4609X-101-103LF		
1	SW1	TMG-325	SMD-Taster 1NO 12V 50mA 4.3mm 130gf	Tact Switch	China	Product ID: 1813303037		
1	U1	N014	Quadruple 2-Input Positive-OR Gate	SN74HCT32N	Texas Instruments	SN74HCT32N	DL032D	
1	U2	N014	AND-Gate, 2 Element	SN74HCT08N	TI	SN74HCT08N	DL008D	
1	U3	PDIP28	64-kbit (8 K x 8) 5 V 70 ns CMOS Static RAM - PDIP-28	6264-70	frei	6264-70		
1	U4	N016	3-Line to 8-Line Decoder / Demultiplexer	SN74HCT138N	TI	SN74HCT138N		
1	U5	SOT129-1	8052 mit BASIC ROM 8KB, DIP40, 5V	8052AH-BASIC	Intel	8052AH-BASIC	+	
1	U6	PDIP28	64-kbit (8 K x 8) 5 V 70 ns CMOS Static RAM - PDIP-28	SRAM_6264-70/62256	frei	6264-70	AS6C62256-55PCN	1877
1	U7	N0020A	Octal D-Type Latch, 3-State, 4,5 ... 5,5 V, DIL-20	SN74HCT573CN	TI	SN74HCT573CN		
1	U9	DIP-14	USB 2.0 to I2C/UART Protocol Converter with GPIO , PDIP-14	MCP2221A	Microchip	MCP2221A-I/P		1596
1	U10	R-78K	DC/DC Conv SIP3 6.5-36V 5V 1A	R-78K5.0-1.0	Recom	R-78K5.0-1.0		
1	W1	JP2	Jumper 3pin	Jumper 3pin	frei	frei		1564
4	W2, W3, W4, W5	JP2	Jumper 3pin	Jumper 3pin	frei	frei		1564
1	X1	AK500/2	AR-Klemmen 250V 2pol grau	ARK500/2	PTR-Messtechnik	AK500/2DS-5.0-V/GRAU		1576